



DHT / DST SERIES
AC SERVO MOTOR
SPECIFICATION MANUAL

Manual Code: ACSMTR-G1-1002A18A
Revision: A1.8A2 [June 2019]



DISCLAIMER

All specified data subject to change without notice to reflect updates and improvements made to product. DMM Technology Corp. assumes no responsibility for damages resulting from user related errors or improper use of product. Safety precautions should be considered for all applications. The DHT Series AC Servo Motor product line is not designed or certified to ensure safety of personnel or machinery, and should not be used for such tasks. Always design a higher-level safety feedback to reduce the risks of product and bodily harm.

Products from DMM Technology Corp. are supported by the following warranty:

- 1 year from the date of purchase or 14 months from the month of original date shipment from factory.

Within the warranty period, DMM Technology Corp. will replace or repair any defective product free of charge given that the cause of the defect is caused by a manufacturing problem. This warranty does not cover cases involving the following conditions:

- The product is used in an unsuitable or hazardous environment, resulting in damages to the product.
- Improperly handling resulting in physical damage to the product. Including falling, heavy impact, or shock.
- Damages resulting from transportation or shipping after the original factory delivery.
- Unauthorized alterations or modifications made to the product, resulting in damages to the product.
- The encoder has been modified or removed from the factory mounted position.
- Alterations have been made to the Name Plate of the product
- Damages resulting in usage of the product not specified by this manual.
- Damages to the product resulting from natural disasters
- Modifications have been made to the servo motor-end connectors (receptacle for 1.5kW and 2.0kW motors).
- The product has been altered either cosmetically or electronically
- Alterations have been made to the Name Plate of the product.

INSTALLATION AND OPERATION

- Install and mount the servo motor in an environment free of hazardous substances such as flammable fluids or gases, corrosive chemical fluids or gases, or water.
- Ensure that the servo motor will not be subject to large amounts of cooling fluid, oil, or residual metal chips from the machinery.
- Do not subject the motor shaft and cables to large amounts of stress. Including tension, bending, or twisting. Never subject the motor shaft or encoder cover to large impact, such as from a hammer.
- The low voltage servo motor class can experience line voltage drops for longer cable lengths. Contact DMM Technology Corp. if the application experiences such effect and require remedy.
- Do not perform unauthorized modifications to the servo motor body or cables.
- Ensure that the servo motor is not in direct contact with any heat sensitive objects. The motor may generate large amounts of heat after prolonged use and can damage nearby objects.
- In general, the servo motor should be installed and mounted in a well ventilated, low humidity area that will not be subject to significant vibration or shock.
- The motor mounted absolute encoder is tuned and calibrated from the factory. Do not make unauthorized modifications or changes to the encoder.

CERTIFICATION

CE	Machinery Directive 2006/42/EC Low Voltage Directive 2014/35/EU Electromagnetic Compatibility 2014/30/EU EN12100:2010 EN 60034-1:2010; EN 60204-1:2006/AC: 2010 EN 61000-6-1: 2007; EN 61000-6-2:2005/AC: 2005
----	--

Servo Motor Model Designation

DST Series - Metric Frame

640-DST-A6TK1

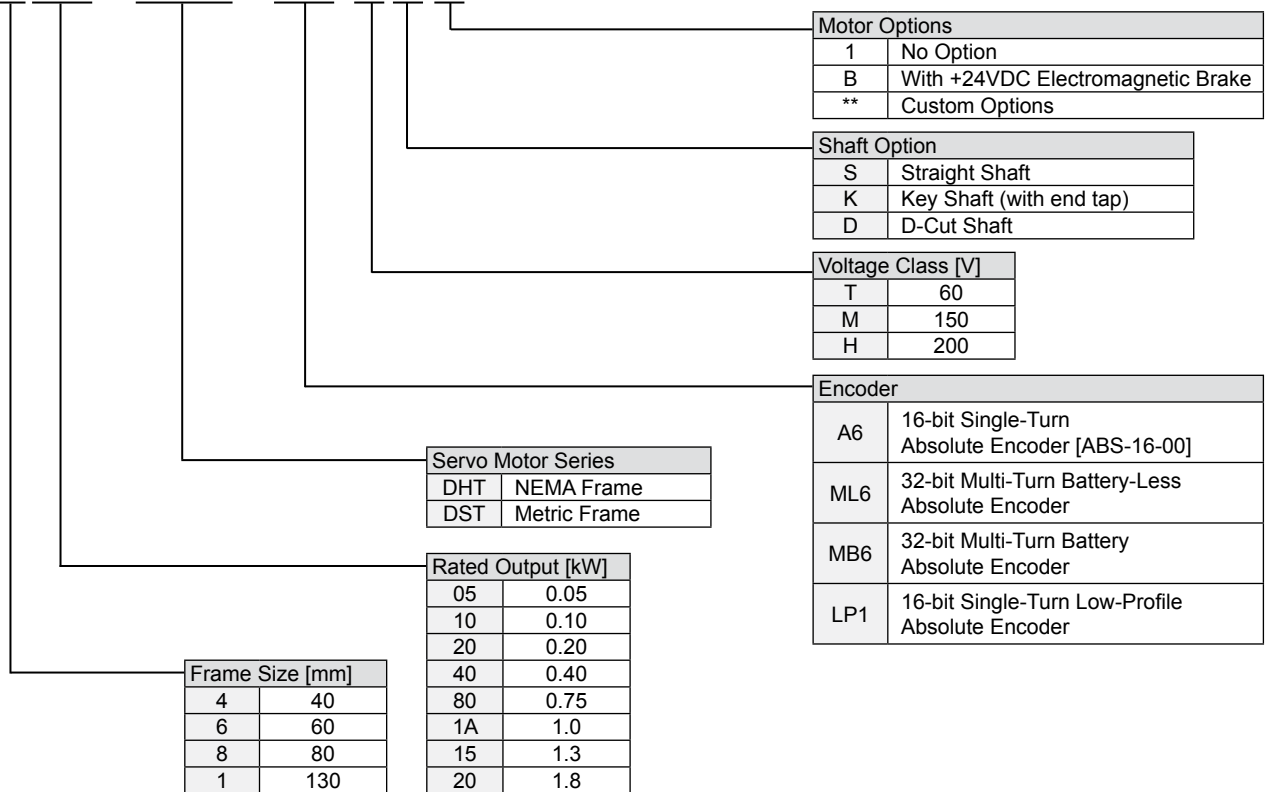

DHT Series - NEMA Frame

86M-DHT-A6MK1

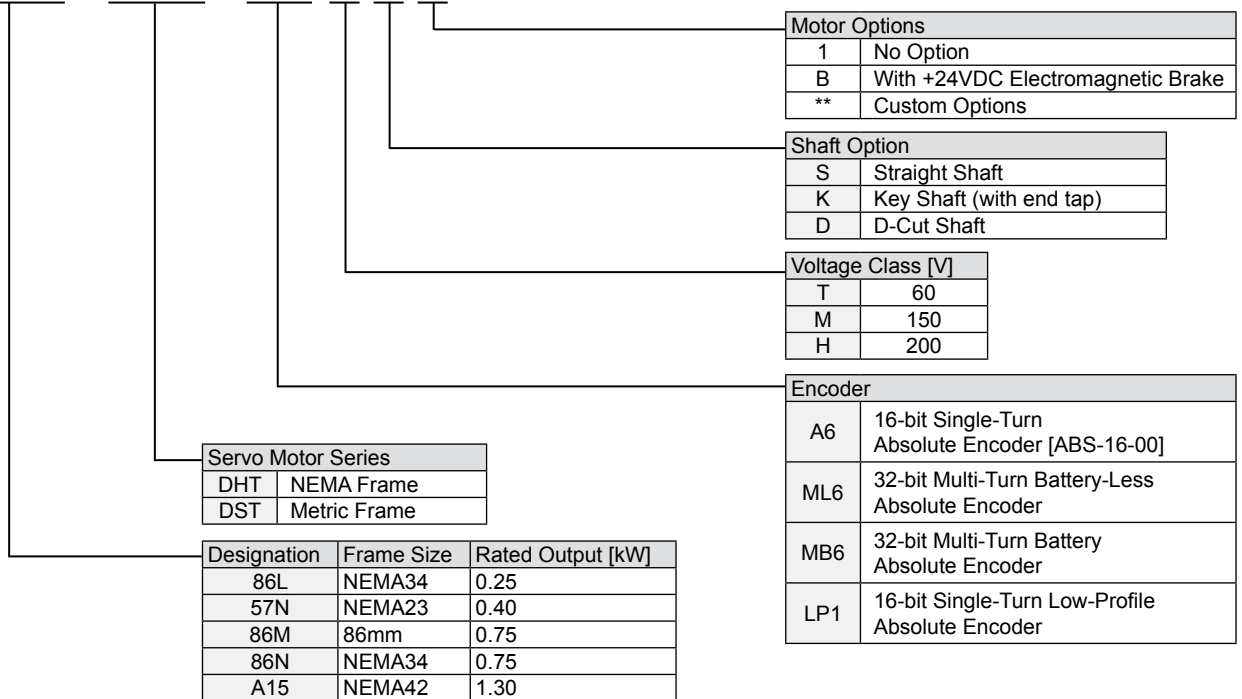

Applicable Servo Drive Pair

Servo Motor Series	Model Name Prefix	Inertia Class	Frame Size	Voltage Class	Applicable Servo Drive
DHT	86L	Medium inertia for low reduction, higher rigidity, slower acceleration applications.	NEMA34	60V	DYN2-TL
	57N	Low inertia for high response, dynamic acceleration rates, high frequency, low rigidity applications	NEMA23	60V	DYN2-TL / DYN4-L01
	86M	Medium inertia for low reduction, higher rigidity, slower acceleration applications.	86mm	150V	DYN2-TL/ DYN4-H01
	86N	Medium inertia for low reduction, higher rigidity, slower acceleration applications.	NEMA34	150V	DYN2-TL/ DYN4-H01
	A15	Medium inertia for low reduction, higher rigidity, slower acceleration applications.	NEMA42	200V	DYN4-T01
DST	405	Low inertia for high response, dynamic acceleration rates, high frequency, low rigidity applications	40mm	60V/ 200V	DYN2-T1/ DYN4-L01
	410			60V/ 200V	DYN2-T1/ DYN4-L01
	620		60mm	60V/ 200V	DYN2-T1/ DYN4-L01
	640			60V/ 200V	DYN2-T1/ DYN4-L01
	880	80mm	200V	DYN4-H01	
	11A	130mm		DYN4-H01	
	115			DYN4-T01	
	120			DYN4-T01	

Consolidated Specifications

Servo Motor Series	Model Name Prefix	Rated Output Capacity [kW]	Frame Size	Voltage Class	Rated Current/ (Peak Current) [A]	Rated Speed/ (Max Speed) [r/min]	Rated Torque/ (Peak Torque) [Nm]	Rotor Inertia (Brake) [kg-cm ²]	Torque Coefficient [Nm/A]	Holding Brake Option	Applicable Servo Drive
DHT	86L	0.25	86mm NEMA34	60V	6.25 (19.8)	3000 (5,000)	0.8 (2.4)	0.65	0.121	X	DYN2-TL
	57N	0.40	57mm NEMA23	60V	8.4 (21.0)	3,000 (5,000)	1.27 (3.82)	0.426 (0.479)	0.182	24VDC	DYN2-TL DYN4-L01 ¹¹
	86M	0.75	86mm	150V	7.2 (21.5)	3,000 (5,000)	2.4 (7.1)	2.45 (2.94)	0.335		DYN2-TL ² DYN4-H01
	86N	0.75	NEMA34	150V	7.2 (21.5)	3,000 (5,000)	2.4 (7.1)	2.45 (2.94)	0.335		DYN2-TL ² DYN4-H01
	A15	1.3	NEMA42	200V	6.0 (18.0)	1,500 (3,000)	4.98 (15)	6.3 (7.56)	0.833		DYN4-T01
DST	405	0.05	□40mm	60V	2.0 (6.0)	3,000 (5,000)	0.16 (0.48)	0.036 (0.044)	0.08		24VDC
				200V	0.61 (2.1)				0.228	DYN4-L01	
	410	0.10	□40mm	60V	3.0 (9.0)	3,000 (5,000)	0.318 (0.955)	0.063 (0.076)	0.106	24VDC	DYN2-T1
				200V	0.84 (2.9)				0.331		DYN4-L01
	620	0.20	□60mm	60V	4.5 (11.3)	3,000 (5,000)	0.64 (1.91)	0.232 (0.278)	0.169	24VDC	DYN2-T1
				200V	1.9 (6.8)				0.28		DYN4-L01
	640	0.40	□60mm	60V	8.4 (21.0)	3,000 (5,000)	1.27 (3.82)	0.426 (0.511)	0.181	24VDC	DYN2-T1
				200V	2.6 (8.3)				0.460		DYN4-L01
	880	0.75	□80mm	200V	4.2 (12.6)	3,000 (5,000)	2.39 (7.16)	2.0 (2.3)	0.568	24VDC	DYN4-H01
	11A	1.0	□130mm		5.3 (15.9)				1,500 (3,000)		4.4 (12)
	115	1.3		8.6 (25.8)	1,500 (3,000)	8.27 (23.3)	18.9 (21.74)	0.903		DYN4-T01	
	120	1.8		10.7 (32.1)				1,500 (3,000)	11.5 (28.7)	23.8 (27.37)	0.894

Note: 1. When paired with the 57N-DHT motor, the DYN4-L01 servo drive is limited to 110/120VAC voltage input.
 2. When paired with the DYN2 servo drive, the peak speed of the 86M and 86N motor depends on the voltage input. For example, at 48VDC input, the motor's peak speed is approximately 1200rpm.

DHT Series AC Servo Motor

Features

- Standard and metric NEMA23, 34 and 42 frame size motors for universal applications
- Factory mounted and tuned ABS-16-00 Absolute Encoder - 16 bits [65,536 ppr]
- High speed serial absolute encoder with 4-wire feedback
- Medium inertia high rigidity applications
- Low cogging, smooth motor coil response
- Robust against shock and vibration - robust magnetic encoder
- Low maintenance

Application Examples

- Machine Tool / CNC
- Y X table
- Lighting / Camera Automation
- Printing / Textile Automation
- Home / Building Automation
- Roller / Conveyor

Motor Options

- +24VDC electromagnetic holding brake
- Straight shaft, keyed shaft, two flat seat (D-Cut) shaft options
- Custom voltage class options

Motor Specification

Motor Model		86L-DHT	57N-DHT	86M-DHT	86N-DHT	A15-DHT
Rated Output	kW	0.25	0.40	0.75	0.75	1.3
Rated Speed	min ⁻¹	3,000	3,000	3,000	3,000	1,500
Maximum Speed	min ⁻¹	5,000	5,000	5,000 ²	5,000 ²	3,000
Rated Torque ³	N•m	0.8	1.27	2.4	2.4	4.98
Peak Torque	N•m	2.4	3.82	7.2	7.2	15
Voltage Class	V	60	60	150	150	200
Rated Current ³	Arms	6.25	8.4	7.2	7.2	6.0
Peak Current	Arms	19.8	21.0	21.5	21.5	18.0
Rotor Moment of Inertia (Brake)	kg•cm ²	0.650	0.426 (0.479)	2.45 (2.94)	2.45 (2.94)	6.3 (7.56)
Torque Constant	N•m/Arms	0.121	0.182	0.335	0.335	0.833
Encoder Option ¹		16-Bit Single-Turn Absolute (65,536 ppr), 32-Bit Multi-Turn Battery, 32-bit Multi-Turn Battery-Less, Low Profile				
Frame Size		86mm NEMA34	57mm NEMA23	86mm NEMA34 (Metric)	86mm NEMA34	110mm NEMA42
Shaft Length	mm	37	21	45	37	64
Shaft Diameter	mm	12.7 (1/2")	6.35 (1/4")	14	12.7 (1/2")	15.87 (5/8")
Mass (Brake)	kg	1.9	1.2 (1.6)	3.1 (3.6)	3.1 (3.6)	6.7 (8.0)
Ingress Protection		IP65	IP65	IP65	IP65	IP65
Insulation		Class F				
Environment	Temperature	0~40°C Ambient temperature -20~50°C Storage				
	Humidity	85% Max. humidity. no condensation				

Note: 1. Standard encoder option is ABS-16-00 Single-Turn absolute magnetic encoder.

2. When paired with the DYN2 servo drive, the peak speed of the 86M and 86N motor depends on the voltage input. For example, at 48VDC input, the motor's peak speed is approximately 1200rpm.

3. Rated torque measured as continuous allowable current at 40°C with 6mmx□200mm aluminum heat sink.

Torque - Speed Curve

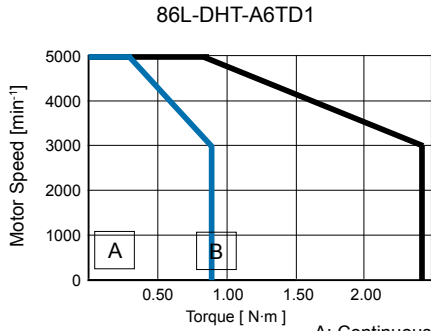

A: Continuous Duty Zone
B: Intermittent Duty Zone

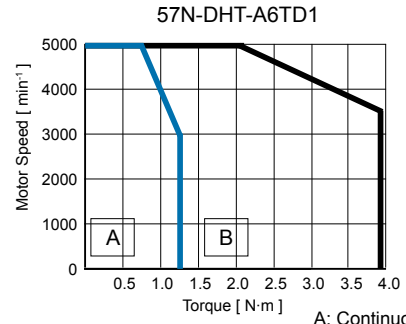

A: Continuous Duty Zone
B: Intermittent Duty Zone

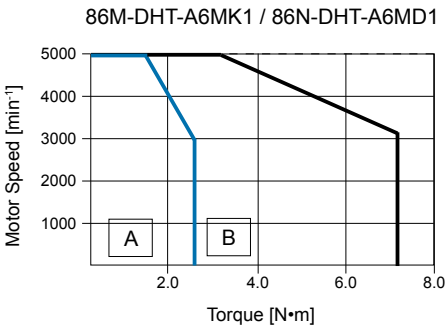

A: Continuous Duty Zone
B: Intermittent Duty Zone

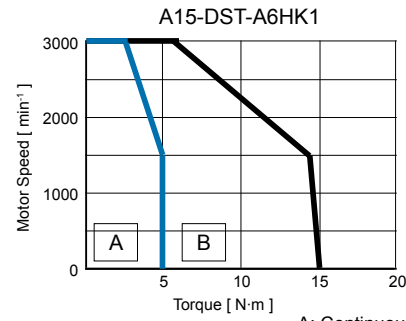

A: Continuous Duty Zone
B: Intermittent Duty Zone

Permissible Radial / Thrust Loads

During testing, installation, mounting or operation, the servo motor shaft should never experience radial or thrust loads exceeding the below specifications. The servo motor shaft must be at least ±0.1mm concentric with coupling and mechanical drive shaft. For belt drive systems, ensure the pinion is as close to the servo motor body as possible to reduce unnecessary force on the servo motor shaft.

Motor Model □□□-DHT	Radial Load F_R [N]	Thrust Load F_S [N]
86L	400	170
57N	240	70
86M / 86N	490	200
A15	600	300

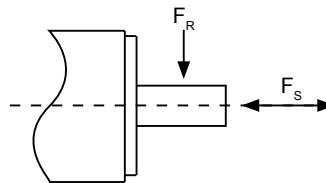

*Permissible radial/thrust load during assembly greater by 10%.

External Dimensions

All Dimensions in [mm]

86L - 250W - NEMA34

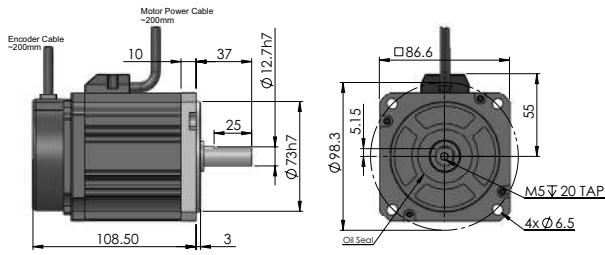

57N - 400W - NEMA23

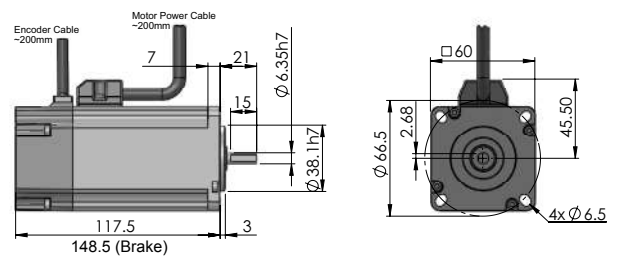

86M - 750W - 86mm

86M-DHT

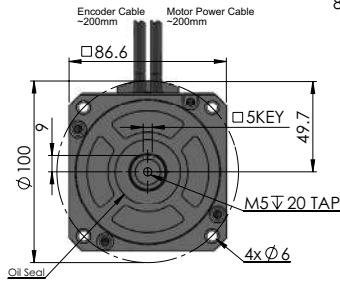
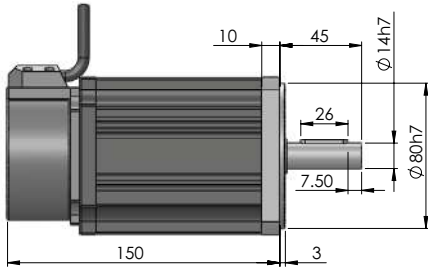

86M-DHT Brake

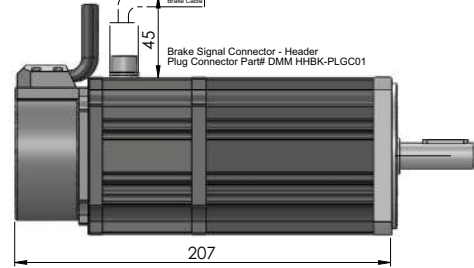

86N - 750W - NEMA34

86N-DHT

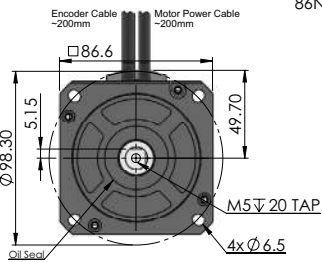
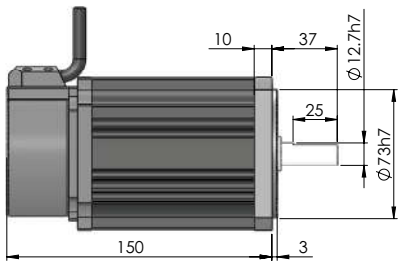

86N-DHT Brake

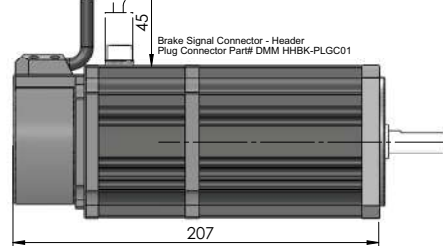

A15 - 1.3kW - NEMA42

A15-DHT

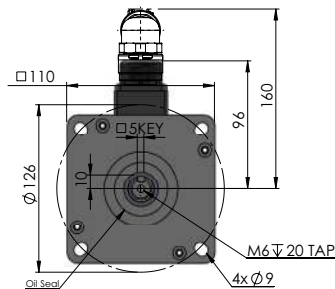
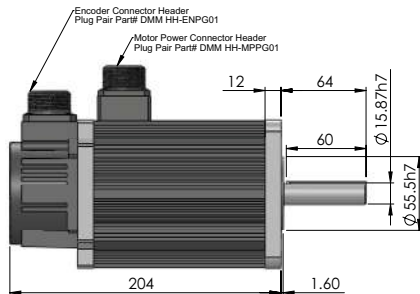

A15-DHT Brake

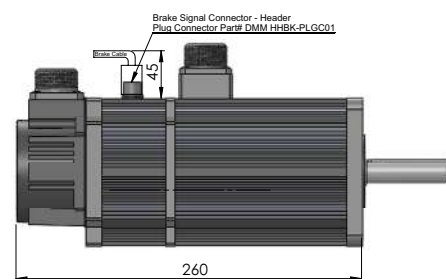

A15-DHT Connector Dimensions

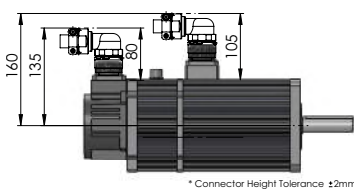

* Connector Height Tolerance ±2mm

Connector Specifications

86L, 57N, 86M, 86N Motor

Motor Power Connector

Part	Part No.	Manufacturer
Connector Assembly	VLP-04V	J.S.T.
Plug Housing	SVF-61T-P2.0	J.S.T.
Socket Contact	SVF-61T-P2.0	J.S.T.
Cable Retainer	VLS-02V	J.S.T.



Looking from connector input side

Pin Layout	Color		Signal
	57N	86L, 86M, 86N	
1	Blue	Blue	Phase A
2	Red	Red	Phase B
3	Black	Yellow	Phase C
4	Yellow/Green		Frame Ground

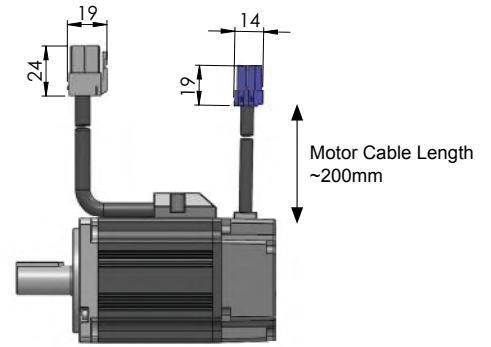

Encoder Connector

Part	Part No.	Manufacturer
Connector Assembly	HILP-04V-1-S	J.S.T.
Plug Housing	HILP-04V-1-S	J.S.T.
Pin Contact	SHIF-01T-P0.5	J.S.T.



Looking from connector input side

Pin Layout	Color	Data
1	Black	Gnd
2	Blue	S-
3	Green	S+
4	Red	+5VDC

Brake Connection

• 57N-DHT

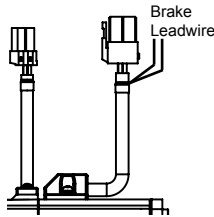

Brake Leadwire Colour	Signal
Brown	+24VDC
White/Black	Ground

• 86M, 86N-DHT

Brake signal header connector Pinout:

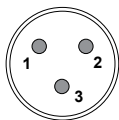

Pin Layout	Signal
1	+24VDC
2	Ground
3	NC

Mating Plug DMM Part# DMM HHBK-PLGC01
* Mating plug included with brake motor

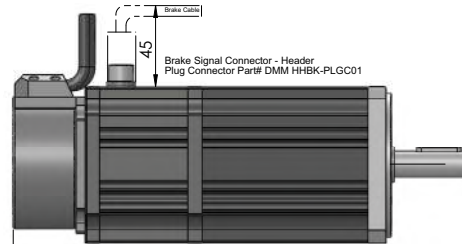

A15 Motor

Motor Power Connector

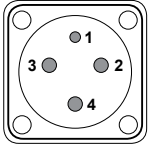

Pin Layout	Signal
1	Frame Ground
2	Motor Phase C
3	Motor Phase B
4	Motor Phase A

Mating Plug DMM Part# DMM HH-MPPG01

Encoder Connector

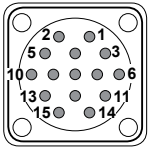

Pin Layout	Data
2	+5VDC
14	Ground
10	S-
6	S+
4	BAT+
12	BAT- (Ground)

Note: Pins 4 and 12 only used on multi-turn encoder with battery.

Mating Plug DMM Part# DMM HH-ENPG01

Brake Connector

Brake signal header connector Pinout:

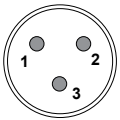

Pin Layout	Signal
1	+24VDC
2	Ground
3	NC

Mating Plug DMM Part# DMM HHBK-PLGC01
* Mating plug included with brake motor

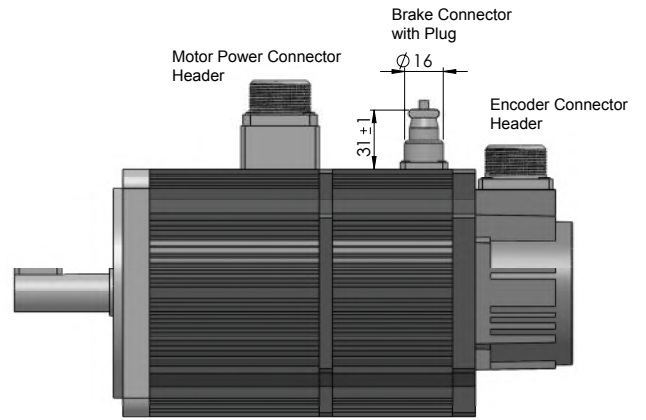

Cable Selection

Motor Model	Servo Drive	Encoder Cable Part#	Encoder Cable Specification	Motor Power Cable Part#	Motor Power Cable Specification	Length
86L	DYN2-TL	CAEN-LH□-TSP	D	CAMP-LH□-SSP	A	□ = 3,5,10,15meter standard lenght option. Custom length options also available.
57N	DYN2-TL	CAEN-LH□-TSP	D	CAMP-LH□-SSP	A	
	DYN4-L01	CAEN-HL□-TSP	E	CAMP-HL□-SSP	B	
86M	DYN2-TL	CAEN-LH□-TSP	D	CAMP-LH□-SSP	A	
	DYN4-H01	CAEN-HL□-TSP	E	CAMP-HL□-SSP	B	
86N	DYN2-TL	CAEN-LH□-TSP	D	CAMP-LH□-SSP	A	
	DYN4-H01	CAEN-HL□-TSP	E	CAMP-HL□-SSP	B	
15A	DYN4-T01	CAEN-HH□-TSP	F	CAMP-HH□-SSP	C	

A / B Type Specification

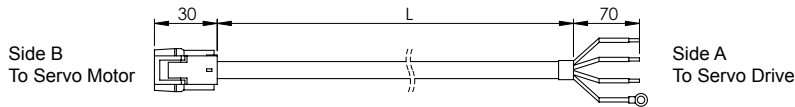

Side B To Servo Motor	
Connector Assembly	VLR-04V
Contact	SVM-61T-P2.0
Manufacturer	J.S.T.

Cable	
Class	600V, 121°C UL1581
Conductor	1.5mm dia. AWG16
Insulator	PVC
O.D.	9mm

Side A To Servo Drive	
Connector	4-Position Lead Wire

C Type Specification

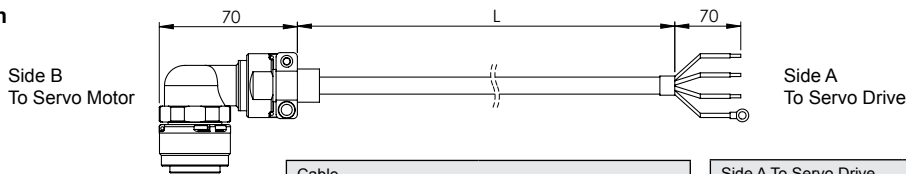

Side B To Servo Motor	
Connector Assembly	4-Position Circular Connector
Contact	
Manufacturer	DMM Part# SPCU-HHMP-4

Cable	
Class	600V, 121°C UL1581
Conductor	1.5mm dia. AWG16
Insulator	PVC
O.D.	9mm

Side A To Servo Drive	
Connector	4-Position Lead Wire

D Type Specification

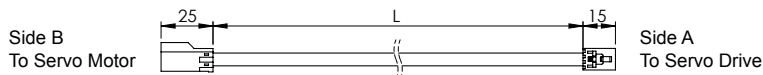

Side B To Servo Motor	
Connector Assembly	HILR-04VF-1-S
Contact	SHIM-01T-P0.5
Manufacturer	J.S.T.

Cable	
Class	30V, 105°C UL20789
Conductor	0.63mm dia. AWG24 2x2 or 3x2 Twisted Pair
Insulator	PVC
O.D.	5.6mm

Side A To Servo Drive	
Connector Assembly	50-57-9404 or equivalent
Contact	16-02-0069 or equivalent
Manufacturer	Molex.

E Type Specification

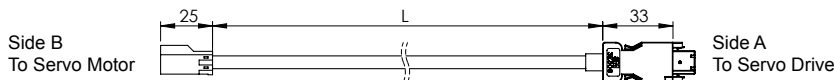

Side B To Servo Motor	
Connector Assembly	HILR-04VF-1-S
Contact	SHIM-01T-P0.5
Manufacturer	J.S.T.

Cable	
Class	30V, 105°C UL20789
Conductor	0.63mm dia. AWG24 2x2 or 3x2 Twisted Pair
Insulator	PVC
O.D.	5.6mm

Side A To Servo Drive	
Connector Assembly	3E206-0100KV
Connector Shell Kit	3E306-3200-008
Manufacturer	3M

F Type Specification

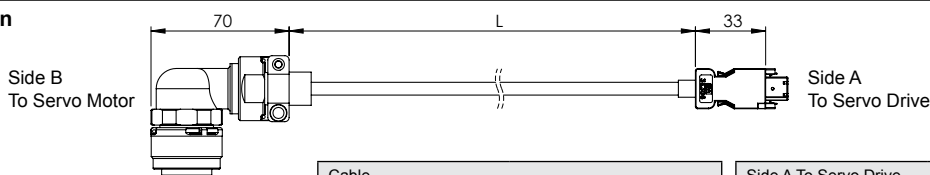

Side B To Servo Motor	
Connector Assembly	15-Position Circular Connector
Contact	
Manufacturer	DMM Part# SPCU-HHEN-15

Cable	
Class	30V, 105°C UL20789
Conductor	0.63mm dia. AWG24 2x2 or 3x2 Twisted Pair
Insulator	PVC
O.D.	5.6mm

Side A To Servo Drive	
Connector Assembly	3E206-0100KV
Connector Shell Kit	3E306-3200-008
Manufacturer	3M

DST Series AC Servo Motor

Features

- Low inertia and medium inertia types
- Standard metric servo frame size
- Factory mounted and tuned ABS-16-00 Absolute Encoder - 16 bits [65,536 ppr]
- High speed serial absolute encoder with 4-wire feedback
- Very low vibration, uniform winding density
- Low voltage 60V and high voltage 200V options
- Robust against shock and vibration - Robust magnetic encoder
- IP65 construction

Application Examples

- Machine Tooling / CNC
- Y X table
- Textile / Embroidery Automation
- Printing / Packaging
- Medical Machine
- Roller / Conveyor Machines
- Battery Powered / EV / Transport
- Lighting / Camera

Motor Options

- +24VDC electromagnetic holding brake
- Straight shaft, key shaft, D-cut shaft options
- Shorter frame option with ultra-thin ABS-16-00 encoder
- Custom voltage class options

Motor Specification

Motor Model □□□-DST		405		410		620		640		880	11A	115	120
Rated Voltage	V	60V	200V	60V	200V	60V	200V	60V	200V	200V			
Rated Output	kW	0.05		0.1		0.2		0.4		0.75	1.0	1.3	1.8
Rated Torque*2	N·m	0.16		0.318		0.64		1.27		2.39	4.7	8.27	11.5
Instantaneous Max. Torque	N·m	0.48		0.955		1.91		3.82		7.16	12	23.3	28.7
Rated Current	A	2.0	0.61	3.0	0.84	4.5	1.9	8.4	2.6	4.2	5.3	8.6	10.7
Max. Current	A	6.0	2.1	9.0	2.9	11.3	6.8	21.0	8.3	12.6	15.9	25.8	32.1
Rated Speed	r/min	3000		3000		3000		3000		3000	1500	1500	1500
Max. Speed	r/min	5000		5000		5000		5000		5000	3000	3000	3000
Rotor Inertia (Brake)	kg·cm ²	0.036 (0.044)		0.063 (0.076)		0.232 (0.278)		0.426 (0.511)		2.0 (2.3)	8.5 (10.2)	18.9 (21.74)	23.8 (27.37)
Torque Coefficient	N·m/A	0.08	0.228	0.106	0.331	0.169	0.28	0.181	0.460	0.568	0.755	0.903	0.894
Mass (Brake)	kg	0.38 (0.50)		0.45 (0.7)		1.1 (1.5)		1.5 (1.9)		2.8 (3.6)	7.7 (9.0)	8.9 (10.0)	10.0 (10.8)
Encoder Option ¹	16-Bit Single-Turn Absolute (65,536 ppr), 32-Bit Multi-Turn Battery, 32-bit Multi-Turn Battery-Less, Low Profile												
Ratings	Time Rating: Continuous Thermal Class: F Excitation Method: Permanent Magnet Insulation Resistance: DC500V, >20MΩ Noise: ≤60dB; No Special Noise												
Environment	Ambient Temperature: 0~40 °C Storage: -20~50°C Ambient Humidity: 20~80% No Condensation												
Enclosure	IP65												
Shock	98m/s ² Max. (10G)												
Applicable Servo Drive		DYN2 - T1	DYN4 - L01	DYN2 - T1	DYN4 - L01	DTN2 - TL	DYN4 - L01	DYN2 - TL	DYN4 - L01		DYN4 - H01		DYN4 - T01

Note: 1. Standard encoder option is ABS-16-00 Single-Turn absolute magnetic encoder.
2. Rated torque measured as continuous allowable current at 40°C with 6mm×200mm aluminum heat sink.

Torque - Speed Curve

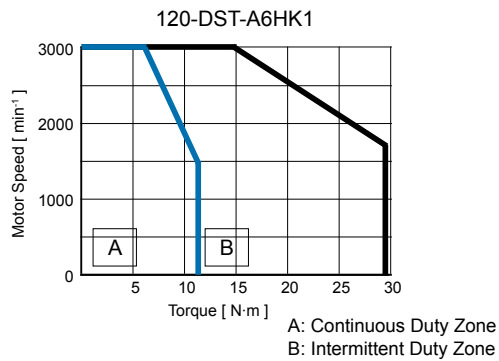
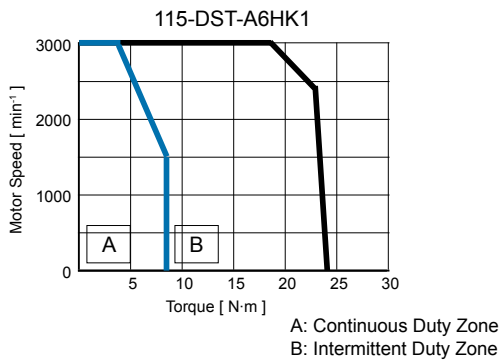
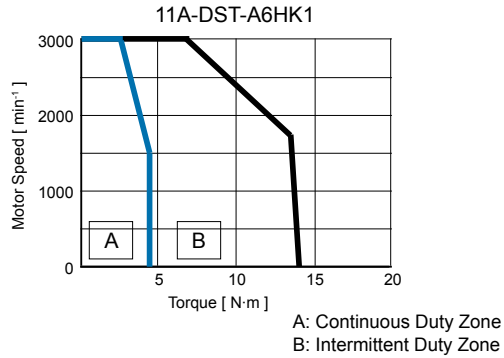
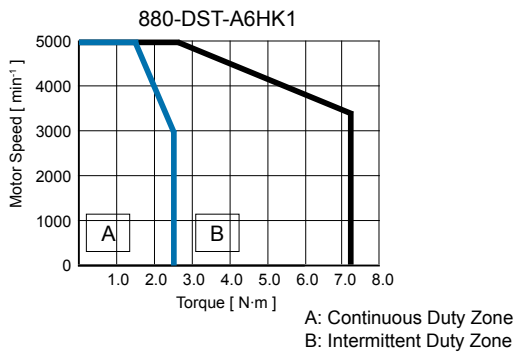
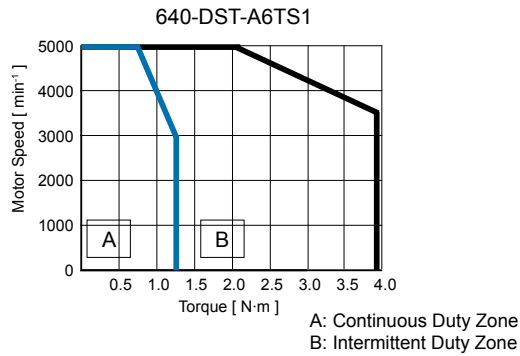
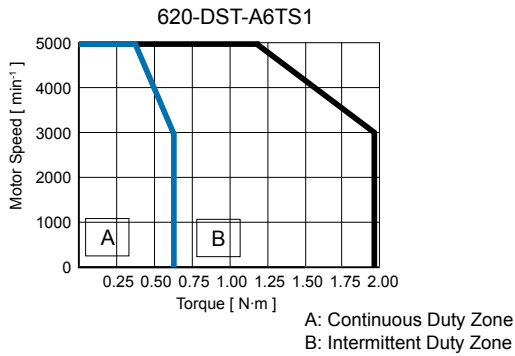
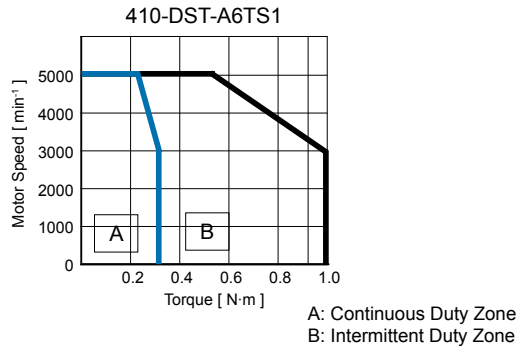
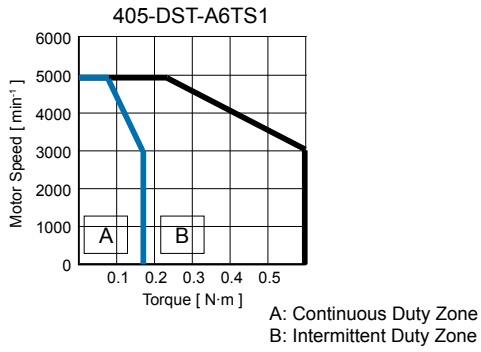

- Notes:
1. Data measured at 40 °C warm-boot conditions.
 2. Torque - Speed characteristic depends on exact supply voltage to servo drive.

External Dimensions

All Dimensions in [mm]

405-DST - 50W - □40mm Frame

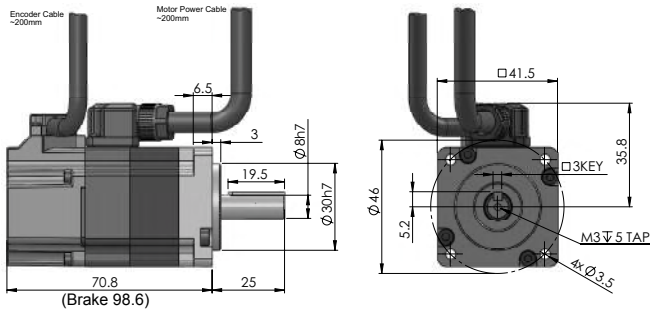

410-DST - 100W - □40mm Frame

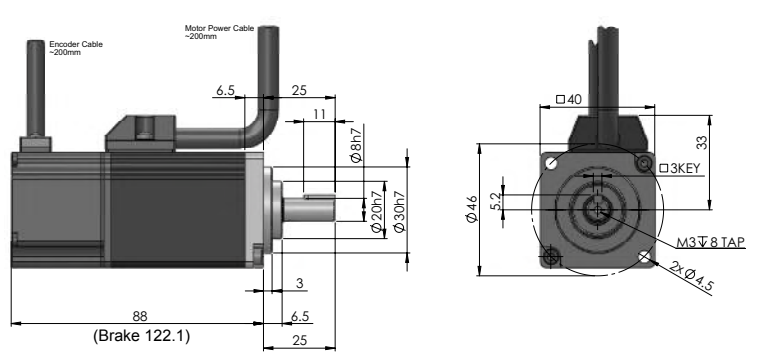

620-DST, 640-DST - 200W,400W - □60mm Frame

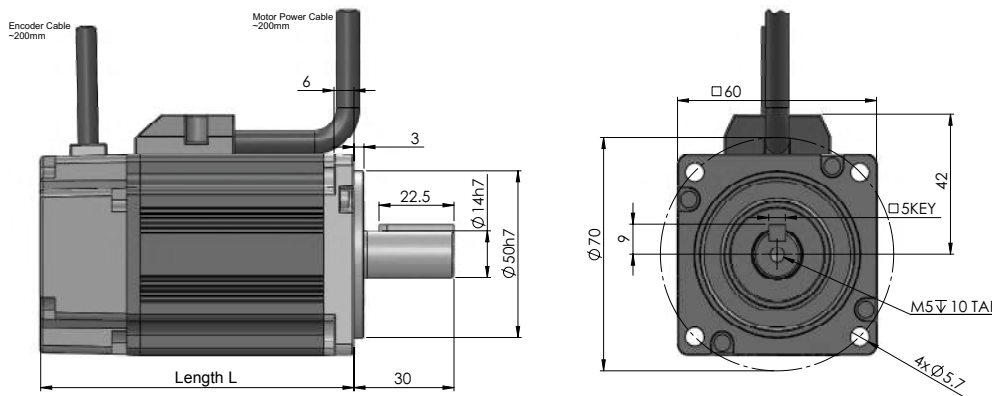

Model	Length L
620-DST	94
620-DST Brake	141
640-DST	122
640-DST Brake	169

880-DST - 750W - □80mm Frame

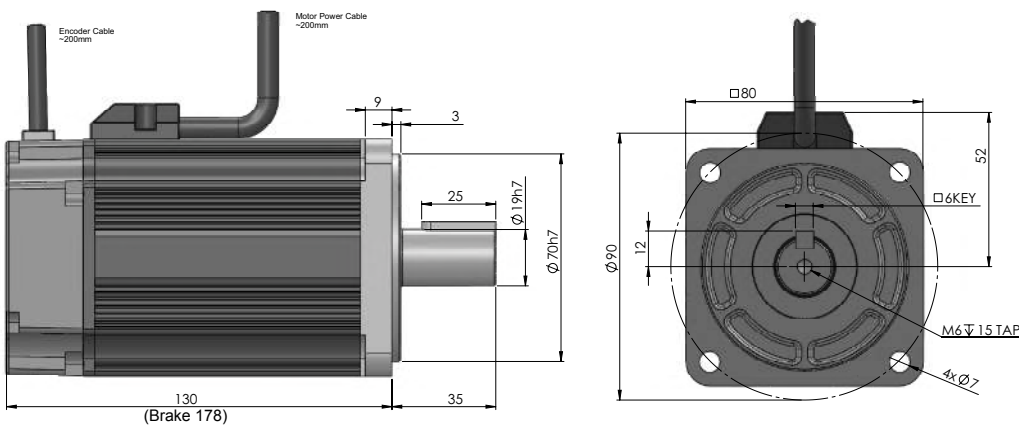

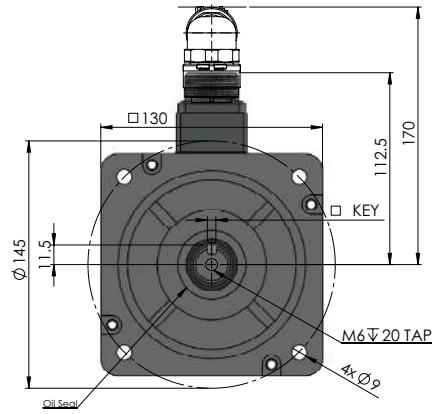
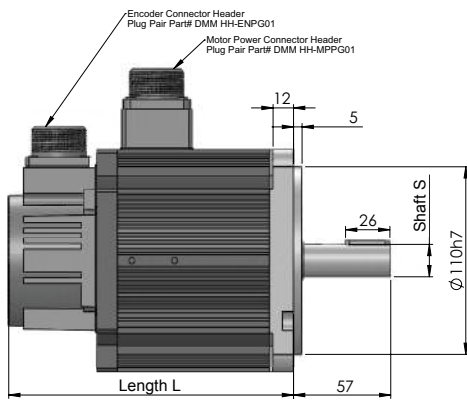

11A, 115, 120-DST Connector Dimensions

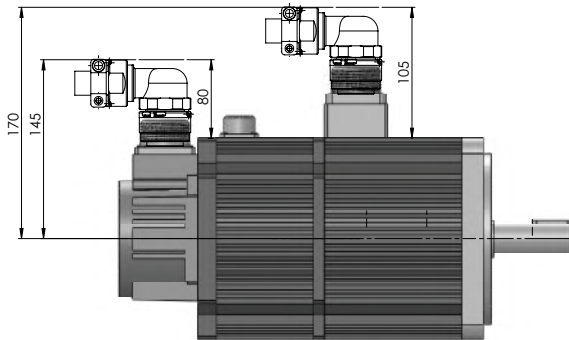

Model	Shaft S	□ KEY	Length L
11A-DST	Ø19h7	5	167
11A-DST Brake	Ø19h7	5	236
115-DST	Ø22h7	6	180
115-DST Brake	Ø22h7	6	248
120-DST	Ø22h7	6	193
120-DST Brake	Ø22h7	6	261

Shaft Dimensions

• With Key and Tap

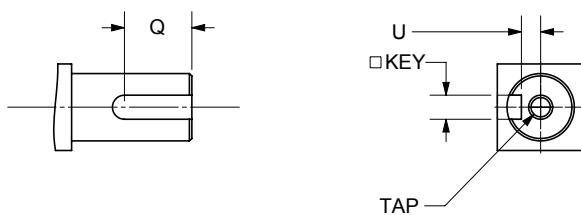

[Unit: mm]

Motor Model	Frame	Q	U	Key	Tap
405-DST-A6□K□	□40mm	14	2.2	3	M3× 5L
410-DST-A6□K□		14	2.2	3	M3× 8L
620-DST-A6□K□	□60mm	14	4	5	M5× 10L
640-DST-A6□K□		14	4	5	M5× 10L
880-DST-A6□K□	□80mm	22	6	6	M6× 15L
11A-DST-A6□K□	□130mm	27	6.5	5	M6× 20L
115-DST-A6□K□		42	7.5	6	M6× 20L
120-DST-A6□K□		42	7.5	6	M6× 20L

Permissible Radial / Thrust Loads

During testing, installation, mounting or operation, the servo motor shaft should never experience radial or thrust loads exceeding the below specifications. The servo motor shaft must be at least ±0.1mm concentric with coupling and mechanical drive shaft. For belt drive systems, ensure the pinion is as close to the servo motor body as possible to reduce unnecessary force on the servo motor shaft.

Motor Model □□□-DST	Radial Load F_R [N]	Thrust Load F_S [N]
405	75	52
410	75	52
620	240	70
640	240	70
880	300	98
11A	600	300
115	680	340
120	980	390

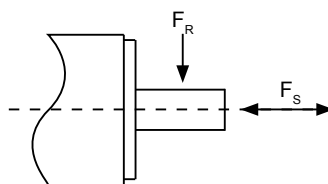

*Permissible radial/thrust load during assembly greater by 10%.

Connector Specification

40mm, 60mm, 80mm Frame Motor

Motor Power Connector

Part	Part No.	Manufacturer
Connector Assembly	VLP-04V	J.S.T.
Plug Housing	SVF-61T-P2.0	J.S.T.
Socket Contact	SVF-61T-P2.0	J.S.T.
Cable Retainer	VLS-02V	J.S.T.

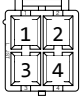

Looking from connector input side

Pin Layout	Color		Signal
	57N	86L, 86M, 86N	
1	Blue	Blue	Phase A
2	Red	Red	Phase B
3	Black	Yellow	Phase C
4	Yellow/Green		Frame Ground

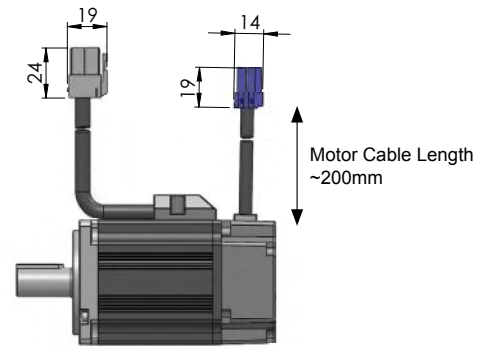

Encoder Connector

Part	Part No.	Manufacturer
Connector Assembly	HILP-04V-1-S	J.S.T.
Plug Housing	SHIF-01T-P0.5	J.S.T.
Pin Contact	SHIF-01T-P0.5	J.S.T.

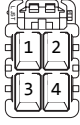

Looking from connector input side

Pin Layout	Color	Data
1	Black	Gnd
2	Blue	S-
3	Green	S+
4	Red	+5VDC

Brake Connection

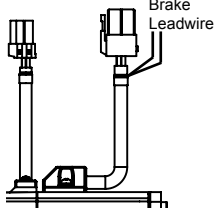

Brake Leadwire

Brake Leadwire Colour	Signal
Brown	+24VDC
White/Black	Ground

130mm Frame Motor

Motor Power Connector

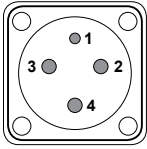

Pin Layout	Signal
1	Frame Ground
2	Motor Phase C
3	Motor Phase B
4	Motor Phase A

Mating Plug DMM Part# DMM HH-MPPG01

Encoder Connector

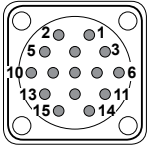

Pin Layout	Data
2	+5VDC
14	Ground
10	S-
6	S+
4	BAT+
12	BAT- (Ground)

Note: Pins 4 and 12 only used on multi-turn encoder with battery.

Mating Plug DMM Part# DMM HH-ENPG01

Brake Connector

Brake signal header connector Pinout:

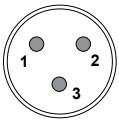

Pin Layout	Signal
1	+24VDC
2	Ground
3	NC

Mating Plug DMM Part# DMM HHBK-PLGC01
* Mating plug included with brake motor

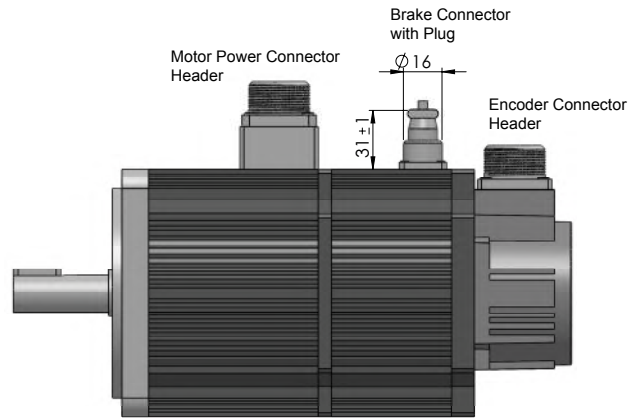

Cable Selection

CAEN-LH3-TSP

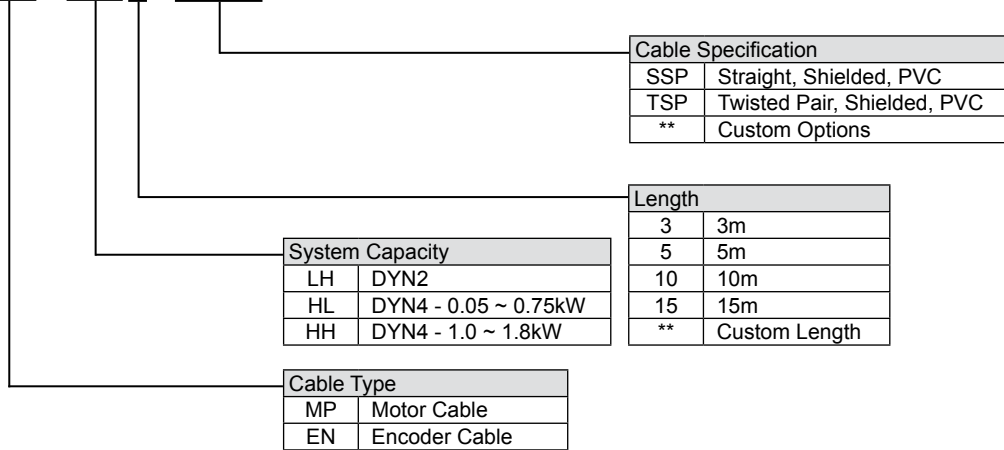

• Motor Power Cables

Servomotor Rated Output	Applicable Servo Drive	Part Number	Length [L]	Specification
0.05 ~ 0.75kW	DYN2	CAMP-LH3-SSP	3m	(A)
		CAMP-LH5-SSP	5m	
		CAMP-LH10-SSP	10m	
		CAMP-LH15-SSP	15m	
0.05 ~ 0.75kW	DYN4	CAMP-HL3-SSP	3m	(B)
		CAMP-HL5-SSP	5m	
		CAMP-HL10-SSP	10m	
		CAMP-HL15-SSP	15m	
1.0 ~ 1.8kW	DYN4	CAMP-HH3-SSP	3m	(C)
		CAMP-HH5-SSP	5m	
		CAMP-HH10-SSP	10m	
		CAMP-HH15-SSP	15m	

A / B Type Specification

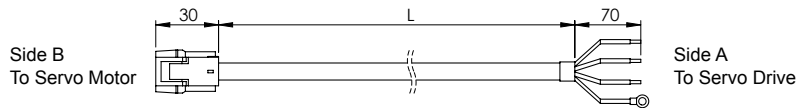

Side B To Servo Motor	
Connector Assembly	VLR-04V
Contact	SVM-61T-P2.0
Manufacturer	J.S.T.

Cable	
Class	600V, 121°C UL1581
Conductor	1.5mm dia. AWG16
Insulator	PVC
O.D.	9mm

Side A To Servo Drive	
Connector	4-Position Lead Wire

C Type Specification

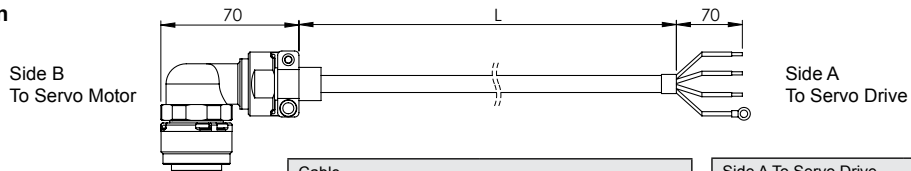

Side B To Servo Motor	
Connector Assembly	4-Position Circular Connector
Contact	
Manufacturer	DMM Part# SPCU-HHMP-4

Cable	
Class	600V, 121°C UL1581
Conductor	1.5mm dia. AWG16
Insulator	PVC
O.D.	9mm

Side A To Servo Drive	
Connector	4-Position Lead Wire

Encoder Cables

Servomotor Rated Output	Applicable Servo Drive	Part Number	Length [L]	Specification
0.05 ~ 0.75kW	DYN2	CAEN-LH3-TSP	3m	(D)
		CAEN-LH5-TSP	5m	
		CAEN-LH10-TSP	10m	
		CAEN-LH15-TSP	15m	
0.05 ~ 0.75kW	DYN4	CAEN-HL3-TSP	3m	(E)
		CAEN-HL5-TSP	5m	
		CAEN-HL10-TSP	10m	
		CAEN-HL15-TSP	15m	
1.0 ~ 1.8kW	DYN4	CAEN-HH3-TSP	3m	(F)
		CAEN-HH5-TSP	5m	
		CAEN-HH10-TSP	10m	
		CAEN-HH15-TSP	15m	

D Type Specification

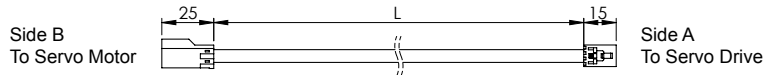

Side B To Servo Motor	
Connector Assembly	HILR-04VF-1-S
Contact	SHIM-01T-P0.5
Manufacturer	J.S.T.

Cable	
Class	30V, 105°C UL20789
Conductor	0.63mm dia. AWG24 2x2 or 3x2 Twisted Pair
Insulator	PVC
O.D.	5.6mm

Side A To Servo Drive	
Connector Assembly	50-57-9404 or equivalent
Contact	16-02-0069 or equivalent
Manufacturer	Molex.

E Type Specification

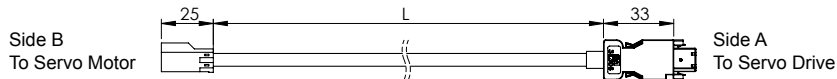

Side B To Servo Motor	
Connector Assembly	HILR-04VF-1-S
Contact	SHIM-01T-P0.5
Manufacturer	J.S.T.

Cable	
Class	30V, 105°C UL20789
Conductor	0.63mm dia. AWG24 2x2 or 3x2 Twisted Pair
Insulator	PVC
O.D.	5.6mm

Side A To Servo Drive	
Connector Assembly	3E206-0100KV
Connector Shell Kit	3E306-3200-008
Manufacturer	3M

F Type Specification

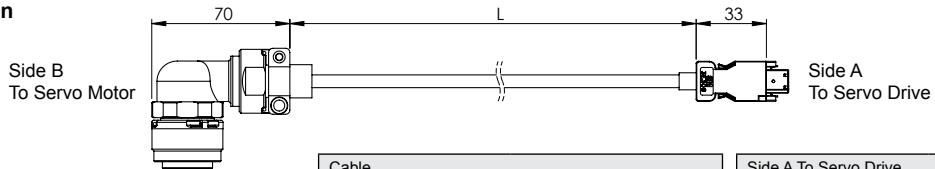

Side B To Servo Motor	
Connector Assembly	15-Position Circular Connector
Contact	
Manufacturer	DMM Part# SPCU-HHEN-15

Cable	
Class	30V, 105°C UL20789
Conductor	0.63mm dia. AWG24 2x2 or 3x2 Twisted Pair
Insulator	PVC
O.D.	5.6mm

Side A To Servo Drive	
Connector Assembly	3E206-0100KV
Connector Shell Kit	3E306-3200-008
Manufacturer	3M

3D CAD Model Download

Please refer to DMM website for latest 3D CAD file downloads in .STP format.

Download Page Link: http://dmm-tech.com/cad_download.html

DOCUMENT REVISIONS

Date	Revision No.	Int. Ref.	Page.	Content
June 2019	1.8A	G2	All sections	<ul style="list-style-type: none"> - Revised servo motor model number designation - Added A15 NEMA42 motor specification - Updated 410 100W motor model - Updated 86L 250W motor model and specification - Updated all dimension drawings - Added Pinout for circular connectors - Added cable pair data and cable specifications.
October 2017	1.7A	G1	All sections	<ul style="list-style-type: none"> - Added 57N-DHT, 86N-DHT servo motor specification. - Updated European Conformity (CE) Records.
November 2016	A1.5B	CA	12, 14, 21 13	130mm Servo Motor Dimension Update (2) Connector Specification Update
August 2015	A1.5	GL	3 4 6, 11, 12 17~21 13 All sections Back Cover	<ul style="list-style-type: none"> Updated: Inertia information for 130mm servomotors Added: Output capacity line-up Correction: Motor dimensions Correction: Motor dimensions Correction: Spelling Added: Dimensions for DST servomotor Updated: Address Information
May 2015	A1.4	H1	All sections	<ul style="list-style-type: none"> Added: Inertia specifications for 130mm DST servomotors Updated: Drawing for DHT servomotors Added: All key and D-cut shaft options Added: Cable options Added: Consolidated motor specifications
January 2015	A1		First Copy	

DHT / DST SERIES
AC SERVO MOTOR
SPECIFICATION MANUAL

Manual Code: ACSMTR-G1-1002A18A
Revision: A1.8A2 [June 2019]
Electronic Version

Copyright © 2019 DMM Technology Corp.

DMM TECHNOLOGY CORP.

120 - 21320 Gordon Way Richmond, British Columbia V6W1J8 Canada

PHONE: +1 604-370-4168

FAX: +1 604-285-1989

WEB: <http://www.dmm-tech.com>

SALES: sales@dmm-tech.com

INFO: info@dmm-tech.com



Dynamic Motor Motion
Technology Corporation

